

## The RT-150 Series III Submittal Data

Project:

Date:

Architect:

Engineer:

Contractor:

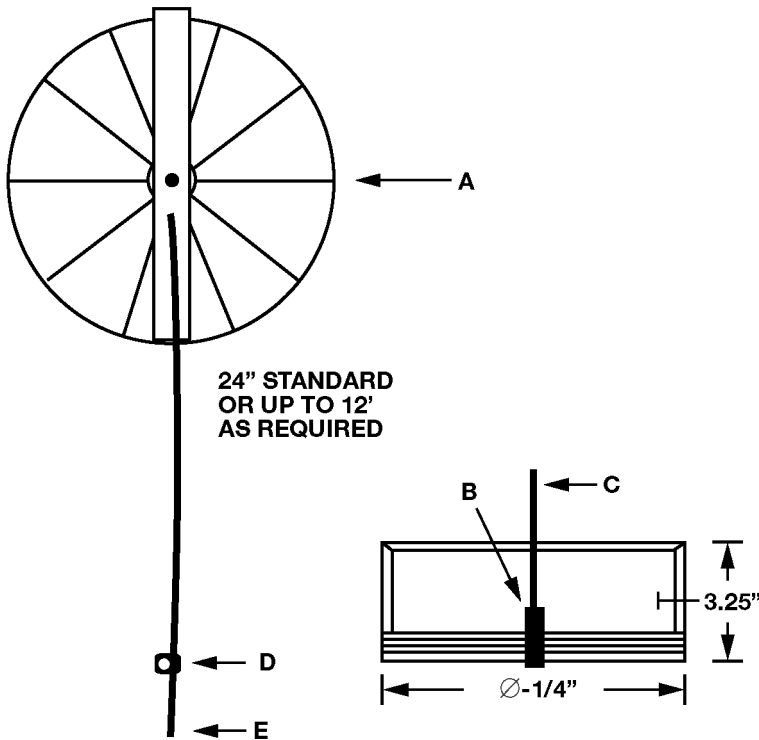

### Design & Materials

- A. Galvanized steel radial damper velocity loaded to hold setting. Also available in aluminum and stainless steel.
- B. Damper pivot accepts rotary cable.
- C. Cable lengths as required up to 12'. 1/4" brass plated steel rotary cable.
- D. Nylon cable clamp for field furnished with 5/16" hex self-drilling screw.
- E. Male square rotary cable end adjusts with a standard hex nut driver (by others) or the MAT square nut driver. Optional: thin-blade screwdriver adjusted cable tip.

### Features

- Furnished one piece for easy installation.
- Cable minimum turn radius = 4".
- Operating temperature limits = -40° to 240° F.
- Maximum recommended velocity = 1600 FPM.
- No linkages or cable to adjust.
- No small loose parts to get lost.
- Dampers may be installed in any plane.
- See Model RT-100 for square/rectangular damper units.

US PATENT #5,702,298  
CANADIAN PATENT #2,185,311

### Available Sizes

6Ø / 7Ø / 8Ø / 10Ø / 12Ø / 14Ø / 15Ø

Location/System	Qty.	Duct Nominal Dia.	Material	Cable Length	Miscellaneous