

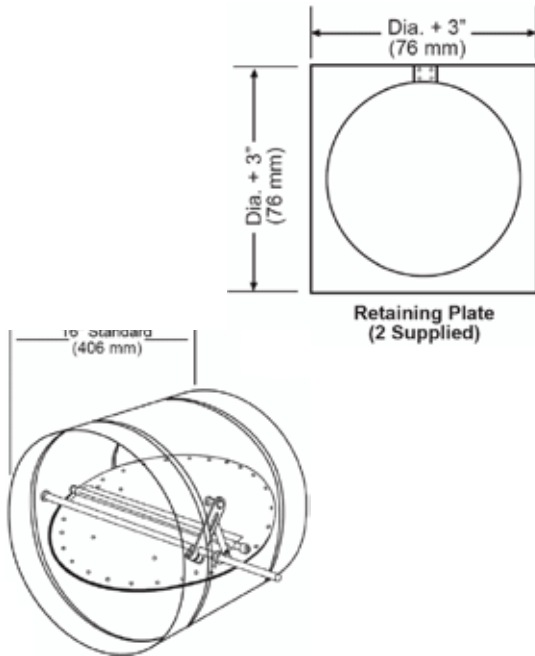

Model F/S-RD-I True Round Combo Fire/Smoke Damper

UL 555 Classified 1.5 & 3 hour rated, UL 555S Classified Class I Leakage (low pressure drop airfoil blade per AMCA standard 500-D)



Application

- The F/S-RD-I series Combination Fire/Smoke Dampers have been designed and tested to exceed all UL and N.F.P.A. requirements for fire dampers as well as smoke dampers. They are intended for use where building codes call for a fire damper to also operate as a smoke damper.
- UL 555 Classified and labeled as a 1-1/2 hour fire damper.
- UL Classified for vertical and horizontal mountings.
- UL 555S Classified and labeled as a Leakage Class I rated Smoke Damper with airflow in both directions. Class I provides for a maximum leakage of 8 cfm per sq. ft at 4.0 inches static pressure.
- UL 555S Classified at 250 °f or 350 °f depending upon motor/operator
*see motor/operator schedule

Standard Construction

- Frame: Roll-formed galvanized steel, 16" (406 mm) long, integral sleeve.
- Blades: Double thickness galvanized steel, 14 ga. equivalent with welded channel reinforcement.
- Bearings: Bronze Oilite press-fit into frame.
- Axles: 3/8" (9.5 mm) square plated steel.
- Seals: Pressure sensitive 450 °F silicone sandwiched between blades.
- Linkage: Jackshaft to blade.
- Controlled Closure Devices: (Heat Activated)
 - EFL - 165 °F Standard, 212, 250, 350 °F
 - PFL - 165 °F Standard, 212 °F available
- Finish: Mill galvanized.
- Retaining Plates: (2) 20 ga. galvanized steel complete with angle clips.
- Maximum Velocity: 2000 fpm (10.2 m/s) on all sizes
- Maximum Pressure: 4" wg (1kPa)

Suggested Specifications

Combination Fire/Smoke Dampers shall be Model: F/S-RD-I by Metropolitan Air Technology. Fire/Smoke Dampers shall bear the Underwriter Laboratories labels for both Fire Dampers and Smoke Dampers. UL 555S rating shall be Class I with Leakage in cfm per sq. ft. not to exceed 8 cfm per sq. ft. at 4.0 inches static pressure for any size.

Manufacturers Recommendations

It is recommended the damper must be inspected and cycled at intervals not greater than every twelve months or in accordance with NFPA 80, 90A, 92A, local codes and the actuator manufacturer.

Notes

Retaining plate on operator side of damper is installed at the factory. Dampers are furnished approximately 1/8" (3.2 mm) smaller than given duct dimensions.

Due to continuing research, MAT reserves the right to change specifications without notice.

Min. Size 8" (203 mm) diameter

Max. Size 24" (610mm) diameter

Options

- 20" Sleeve/body
- 24" Sleeve/body
- Actuator
 - Electric
 - Pneumatic, 25 PSI
- Smoke Detector*
 - Ionization
 - Photoelectric

*Must have 24" Sleeve
- DTO/RE w/ MS Package
- Micro-Switch Package
- RCB-1, -2, -3, -4

F/S-RD-I (1-1/2 hour)

6235 South Oak Park Avenue Chicago, IL 60638 USA
Toll free: 800.585.7686 +1.708.552.4040
Fax: +1.708.594.0396 www.metairtech.com

Represented by:



Model F/S-RD-I True Round Combo Fire/Smoke Damper

UL 555 Classified 1-1/2 Hours / UL 555S Classified Class I

Performance Data

Pressure drop testing was done by an independent laboratory to AMCA Standard 500-D, Fig. 5.3 ductwork upstream & downstream.

Leakage obtained in test of 8" diameter and 24" diameter was less than 1 cfm/sq. Ft.

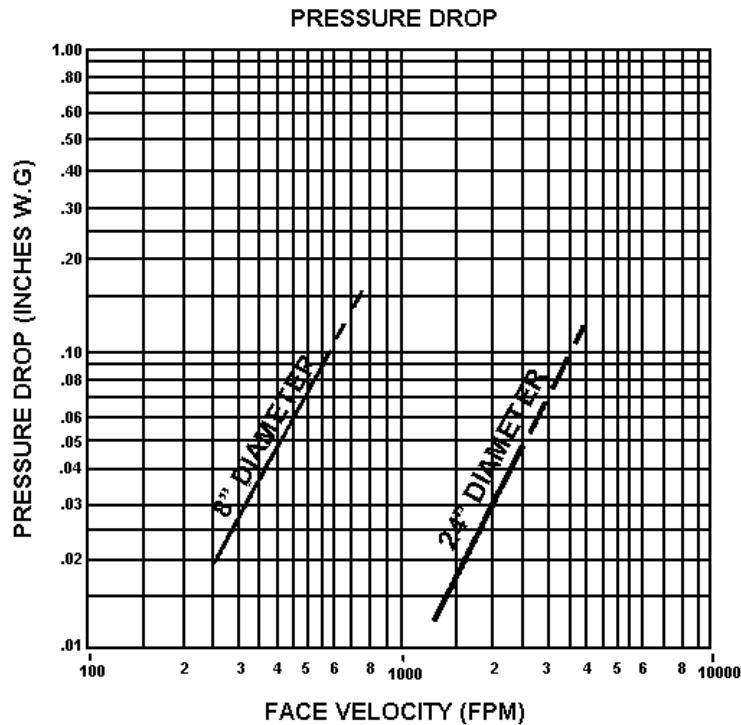

Represented by:

6235 South Oak Park Avenue Chicago, IL 60638 USA
Toll free: 800.585.7686 +1.708.552.4040
Fax: +1.708.594.0396 www.metairtech.com