

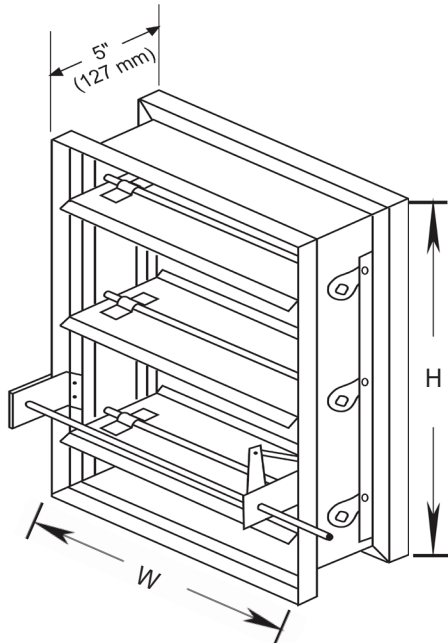

## Model S-3V-II Low Leakage Smoke Damper

UL 555S Classified Class II Leakage Rated



### Suggested Specification

Low Leakage Smoke Control Dampers shall be Model:S-3V-II by Metropolitan Air Technology. Single blade edge and jamb seals shall be of the pressure sensitive type for low leakage. Dampers shall be rated for leakage as to UL 555S rating and shall be Class II with leakage not to exceed 20 cfm per sq. ft. at 4.0 inches static pressure. Linkage shall be of the concealed type for the maximum free area.

### Manufacturer's Recommendations

All moving parts of the damper must be inspected and cycled at intervals not greater than every 12 months or in accordance with the latest edition of NFPA 90A, 92A, local codes and the actuator manufacturer. In addition, the damper shall be inspected for corrosion. Dry lubricants are recommended.

### Notes

Not recommended with blades running vertically.

### Application

- The Model S-3V-II is UL Classified and labeled Class II leakage rated Smoke Damper. Blades are of the 3V shaped or crimped design.
- The damper is approved for airflow in either direction and provides a maximum leakage of 20 cfm/sq. ft at 4" wg. s.p. It has been designed to be installed in a vertical or horizontal mounting position in the duct-work or separate sleeve within 24" of the smoke partition.
- These dampers are approved for use in engineered smoke control systems and are controlled via smoke detection system. Electric (24v, 120v, and 230v) or pneumatic actuators are used to operate the smoke dampers.
- UL 555S Classified at 250 °F or 350 °F depending upon motor/operator \*see motor/operator schedule

### Standard Construction

- Frame: 5" Roll formed Frame - Galvanized Steel hat-section w/staked corners & integral bracing
- Blades: 16 Ga. Roll formed - Galvanized Steel - 3V Blade Design
  - min. width: 4-1/4" (108mm)
  - max. width: 7-1/4" (184mm)
- Axles: Square plated steel
- Seals: Pressure Sensitive 450° silicone blade edge seals and flexible metal jamb seals.
- Linkage: Concealed in frame. Linkage bars are 1/8" (3.2mm)
- Bearings: Bronze Oilite press-fit into frame
- Designed and tested in accordance to standards: UL 555S Classified and listed by UL under File #R27198. They meet all the NFPA-90A, IBC Code, and other major code requirements for Smoke Dampers
- Non-sleeved and side plated dampers are furnished approximately 1/4" (6.4mm) smaller than given duct dimensions. Sleeved dampers are furnished approx. same size as given duct dimension, unless otherwise noted.

### Sizes (duct)

|                               |                               |
|-------------------------------|-------------------------------|
| <b>Min. V or H</b>            | 6" X 6", 152mm X 152mm        |
| <b>Max. Single Section</b>    | 36"W X 48"H, 914mm X 1219mm   |
| <b>Max. Multiple Assembly</b> | 144"W X 96"H, 3657mm X 2438mm |

### Options

- Factory sleeves (20 Ga minimum. 16" min length)(16" X 20 ga. side plate provided if no sleeve is indicated)
- Actuator
  - Electric
  - Pneumatic. 25 psi

Due to continuing research, MAT reserves the right to change specifications without notice.

### S-3V-II

Represented by:

6235 South Oak Park Avenue Chicago, IL 60638 USA  
Toll free: 800.585.7686 +1.708.552.4040  
Fax: +1.708.594.0396 www.metairtech.com