

Models BL-301/BL-301-GR Blast Protection Damper Installation Instructions

Metal/Steel Support Structure

- Where blast damper are specified to be mounted to steel structural members, the specified anchors shall be 304 Stainless steel or galvanized heavy hex bolts and nuts or approved expansion anchors.
- Where possible, structural member requiring blind or hard to reach joints shall use approved expansion bolts designed for steel structural joints.
- Where applicable, structural members may be tapped for a direct bolted joint, provide member being tapped is 1.5-2 times thicker than the diameter of fastener.
- Damper shall not be riveted to steel structural members.
- Heavy-hex nuts should meet the requirements of ASTM A563 (Grade DH; galvanized and lubricated) or ASTM A194 (Grade 2H; galvanized and lubricated). Heavy-hex nut dimensions should meet the requirements of ANSI/ASME B18.2.6. Flat galvanized circular washers should meet the requirements of ASTM F436. Washers should be used under the nut. If the bolt head is to be turned during the tightening procedure, then a washer should also be provided under the head. Lock washers should never be used with high strength bolts. For oversized holes, plate washers 8 mm (5/16 inch) should be used rather than flat washers. Plate washers should be structural grade steel and should be galvanized, if used with galvanized fasteners.
- Compressible-washer-type, direct-tension indicators should meet the requirements of ASTM F959. When the direct-tension-indicator (DTI) is used under the nut, an ASTM F436 washer should be placed between the bolt and the direct-tension indicator. When the direct-tension-indicator is used under the bolt head, an ASTM F436 washer is required under the DTI when the DTI is placed on an oversized hole and between the bolt head and the DTI when the bolt head is the turned element.
- The bolt length used in a connection should be such that the end of the bolt is flush with or projecting beyond the face of the nut when properly installed.
- Nuts and washers should match the steel type of the bolt or fastener. Stainless fasteners should conform to the requirements of ASTM F593, "Standard Specification for Stainless Steel Bolts, Hex Cap Screws, and Studs" and ASTM F594 "Standard Specification for Stainless Steel Nuts."
- Proper consideration should be given to contact between galvanically dissimilar metals.

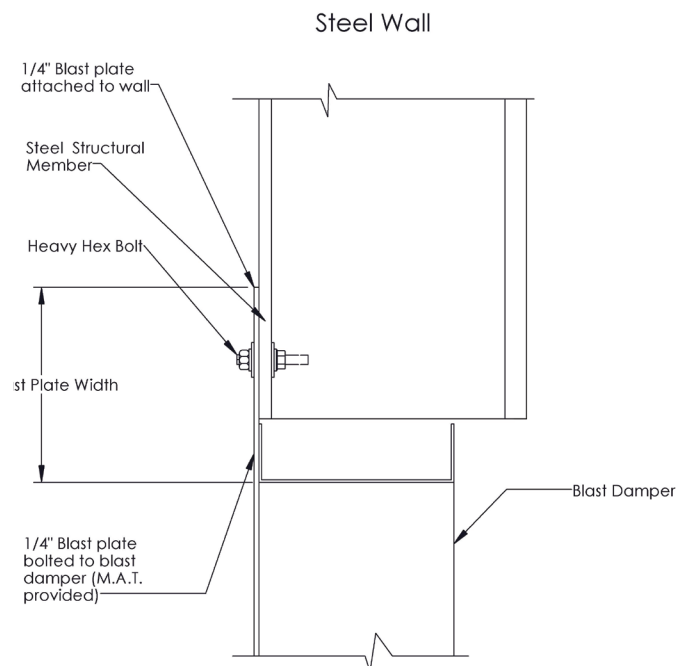

Models BL-301/BL-301-GR Blast Protection Damper Rigging and Lifting Instructions

It is important that workers involved with hoisting and rigging activities are trained in both safety and operating procedures. Hoisting equipment should be operated only by trained personnel.

Four ½” lifting holes are located at the upper corners of each blast damper. These holes are sized to allow the attachment of 5/16 lifting shackles rated at ¾ ton each. It is recommended that all four holes be used when lifting or transporting the

blast dampers. MAT has specified Crosby Screw Pin Shackles [Part #1018419]. The specifications are provided in the product information sheet supplied by Crosby (shown below in this document). If using lift hooks with the shackles, it is recommended that the hooks be fitted with latches. Never wrap a hoist rope around the dampers. Attach the load to only the hook, with slings or other rigging devices. Always test rigging by raising the load slightly to make sure that the load is free and that all sling legs are taking the load.

Lifting locations shown by arrows below

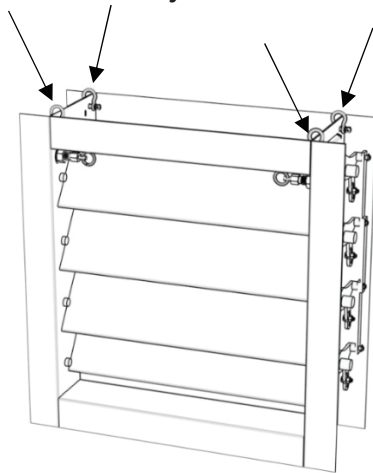

Single Section Damper

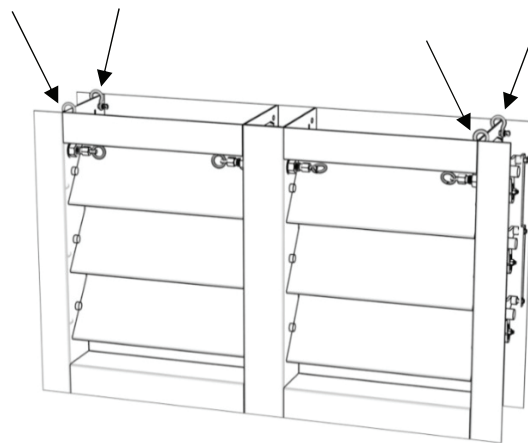

Multi-Section Damper

CROSBY FORGED SHACKLES

Screw Pin Anchor Shackles



G-209 S-209

Screw pin anchor shackles meet the performance requirements of Federal Specification RR-C-271D Type IVA, Grade A, Class 2, except for those provisions required of the contractor.

- Shackles are Quenched and Tempered and can meet DNV impact requirements of 42 joules at -20C.
- Working Load Limit permanently shown on every shackle.
- Forged - Quenched and Tempered, with alloy pin.
- Capacities 1/3 thru 55 metric tons.
- Look for the Red Pin™ . . . the mark of genuine Crosby quality.
- Shackles can be furnished proof tested with certificates to designated standards, such as ABS, DNV, Lloyds, or other certification. Charged for proof testing and certification available when requested at the time of order.
- Hot Dip galvanized or Self-Colored.
- Fatigue Rated.

Nominal Size (in.)	Working Load Limit (t)*	Stock No.		Weight Each (lbs.)	Dimensions (in.)										
		G-209	S-209		A	B	C	D	E	F	G	H	L	M	P
3/16	1/3	1018357	—	.06	.38	.25	.88	.19	.60	.56	.98	1.47	.16	1.12	.19
1/4	1/2	1018375	1018384	.10	.47	.31	1.13	.25	.78	.61	1.28	1.84	.19	1.38	.25
5/16	3/4	1018393	1018400	.19	.53	.38	1.22	.31	.84	.75	1.47	2.09	.22	1.66	.31
3/8	1	1018419	1018428	.31	.66	.44	1.44	.38	1.03	.91	1.78	2.49	.25	2.03	.38
7/16	1-1/2	1018437	1018446	.38	.75	.50	1.69	.44	1.16	1.06	2.03	2.91	.31	2.38	.44
1/2	2	1018455	1018464	.72	.81	.63	1.88	.50	1.31	1.19	2.31	3.28	.38	2.69	.50
5/8	3-1/4	1018473	1018482	1.37	1.06	.75	2.38	.63	1.69	1.50	2.94	4.19	.44	3.34	.69
3/4	4-3/4	1018491	1018507	2.35	1.25	.88	2.81	.75	2.00	1.81	3.50	4.97	.50	3.97	.81
7/8	6-1/2	1018516	1018525	3.62	1.44	1.00	3.31	.88	2.28	2.09	4.03	5.83	.50	4.50	.97
1	8-1/2	1018534	1018543	5.03	1.69	1.13	3.75	1.00	2.69	2.38	4.69	6.56	.56	5.07	1.06
1-1/8	9-1/2	1018552	1018561	7.41	1.81	1.25	4.25	1.16	2.91	2.69	5.16	7.47	.63	5.59	1.25
1-1/4	12	1018570	1018589	9.50	2.03	1.38	4.69	1.29	3.25	3.00	5.75	8.25	.69	6.16	1.38
1-3/8	13-1/2	1018598	1018605	13.53	2.25	1.50	5.25	1.42	3.63	3.31	6.38	9.16	.75	6.84	1.50
1-1/2	17	1018614	1018623	17.20	2.38	1.63	5.75	1.54	3.88	3.63	6.88	10.00	.81	7.35	1.62
1-3/4	25	1018632	1018641	27.78	2.88	2.00	7.00	1.84	5.00	4.19	8.86	12.34	1.00	9.08	2.25
2	35	1018650	1018669	45.00	3.25	2.25	7.75	2.08	5.75	4.81	9.97	13.68	1.22	10.34	2.40
2-1/2	55	1018678	1018687	85.75	4.13	2.75	10.50	2.71	7.25	5.69	12.87	17.84	1.38	13.00	3.13

NOTE: Maximum Proof Load is 2.0 times the Working Load Limit. Minimum Ultimate Strength is 6 times the Working Load Limit. For Working Load Limit reduction due to side loading applications, see page 75.

